

Retrofit-pistons for existing CSC screen changer

2,5x more filtration surface due to new filter cavities

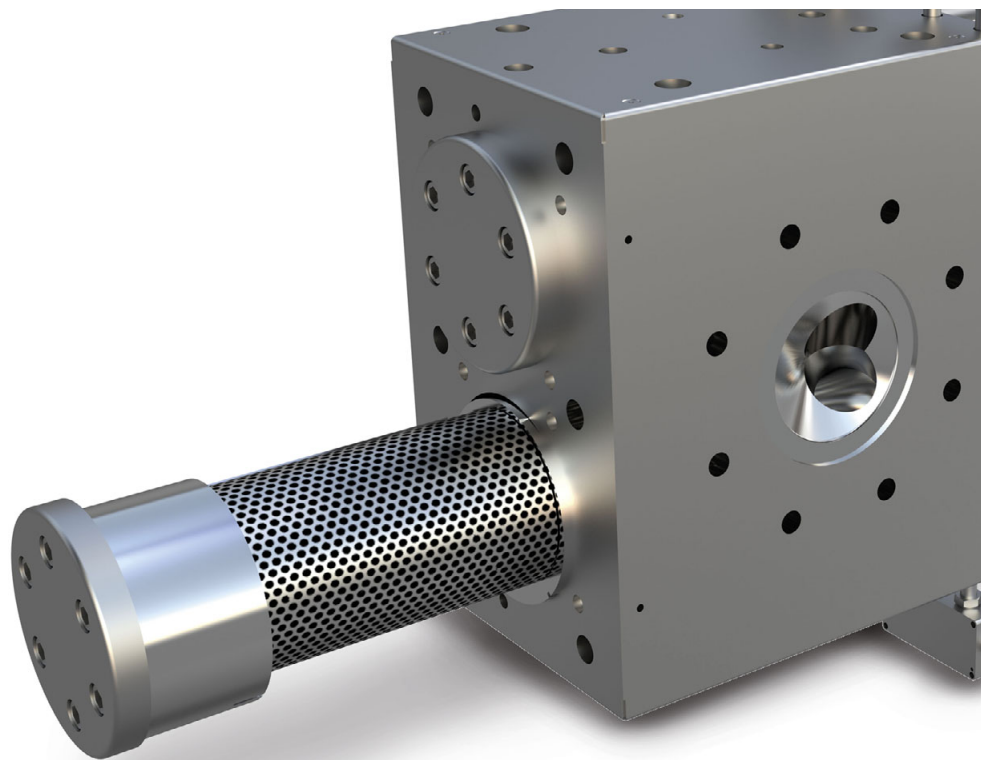

The patent pending arched breaker plate offers up to 2,5 times more active filtration surface than existing pistons with round filter cavities. For retrofitting the screen changer remains in the extrusion line and only the pistons needs to be replaced. Usually this is done by maag service technicians inbetween on day. The filter handling and the venting procedure will remain the same as before.

Your benefits

- Maximation of filtration surface
- Extended screen dwell time
- Higher throughput
- Higher filter fineness
- Lower melt pressure
- Lower flux rate Kg/cm²

Retrofit-pistons for existing CSC screen changer

2,5x more filtration surface due to new filter cavities

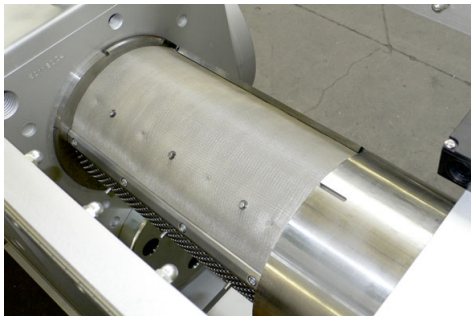
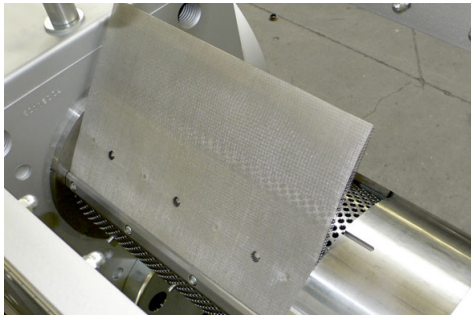
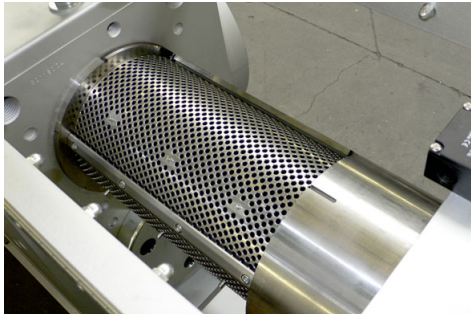

To change the screen, a screen changer piston is moved hydraulically out of the filter housing and the soiled mesh screens are removed, while the other screen changer piston remains in production position. Then new rectangular-cut flat screens are fixed in an arc in clamping grooves and form-fit onto the curved screen plate. The bypass sealing is effected in the same way as with conventional circular CSC screens. When the piston is moved back into the filter housing the screen cavity is preflooded at predetermined positions and vented so that no air penetrates into the melt stream. During the short-time screen change process the melts flows via the remaining screen changer piston, ensuring continuous extrusion.

Existing screen changer	Existing filter area cm ²	New filter area cm ²	Equal to CSC-size
CSC-096	2 x 72	2 x 172	CSC-148
CSC-116	2 x 106	2 x 253	CSC-176
CSC-125	2 x 123	2 x 296	CSC-200
CSC-148	2 x 173	2 x 418	CSC-230
CSC-176	2 x 244	2 x 596	CSC-270
CSC-200	2 x 314	2 x 776	CSC-300
CSC-230	2 x 416	2 x 1041	CSC-340
CSC-250	2 x 491	2 x 1249	CSC-400
CSC-270	2 x 572	2 x 1479	CSC-430
CSC-300	2 x 707	2 x 1854	CSC-490
CSC-340	2 x 908	2 x 2416	CSC-560
CSC-400	2 x 1256	2 x 3393	CSC-660

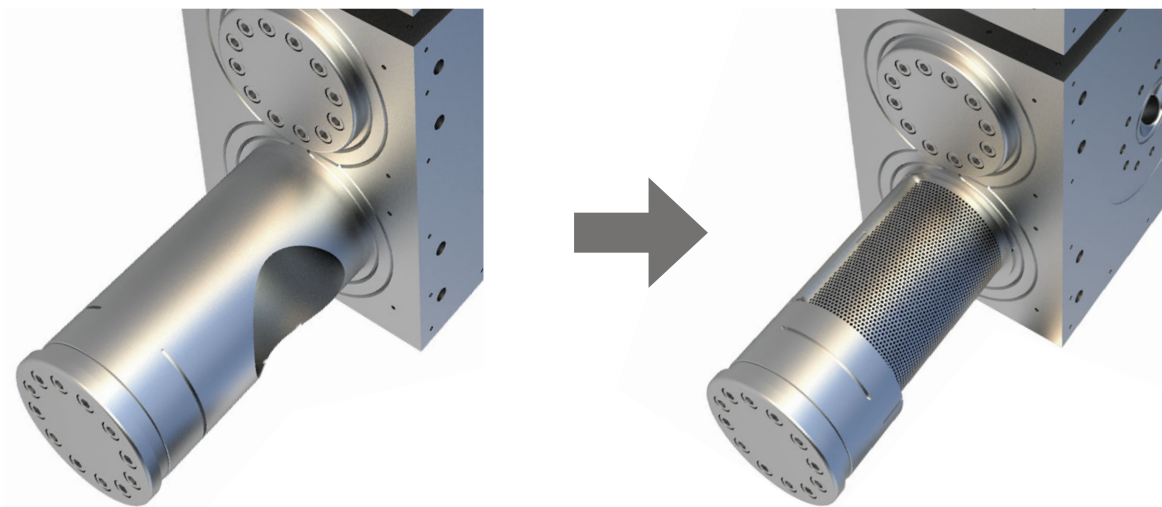

Retrofit-pistons are available for any size of CSC screen changer

maag
 pump systems

automatik
 pelletizing systems

maag
 industrial pumps

Global contacts, see www.maag.com
 Contact us at contact@maag.com